



Palladium® P-39F
Owner's Manual



Important Safety Instructions

1. READ these instructions.
2. KEEP these instructions.
3. HEED all warnings.
4. FOLLOW all instructions.
5. DO NOT use this apparatus near water.
6. CLEAN ONLY with dry cloth.
7. DO NOT block any ventilation openings. Install in accordance with the manufacturer's instructions.
8. DO NOT install near any heat sources such as radiators, heat registers, stoves, or other apparatus (including amplifiers) that produce heat.
9. ONLY USE attachments/accessories specified by the manufacturer.
10. USE only with a cart, stand, tripod, bracket, or table specified by the manufacturer, or sold with the apparatus. When a cart is used, use caution when moving the cart/apparatus combination to avoid injury from tip-over. 
11. UNPLUG this apparatus during lightning storms or when unused for long periods of time.
12. REFER all servicing to qualified service personnel. Servicing is required when the apparatus has been damaged in any way, such as power-supply cord or plug is damaged, liquid has been spilled or objects have fallen into the apparatus, the apparatus has been exposed to rain or moisture, does not operate normally, or has been dropped.



This symbol indicates that there are important operating and maintenance instructions in the literature accompanying this unit.



This symbol indicates that dangerous voltage constituting a risk of electric shock is present within this unit. **WARNING:** To reduce the risk of fire or electrical shock, do not expose this apparatus to rain or moisture.

WARNING: Voltages in this equipment are hazardous to life.

No user-serviceable parts inside. Refer all servicing to qualified service personnel.

CAUTION: Changes or modifications not expressly approved by the manufacturer could void the user's authority to operate.



General Cautions

- When making or changing any connections to your system, switch all the electronics OFF.
 - Do NOT listen to music for long periods at extreme volume settings. Doing so can permanently damage your hearing.
 - When running loudspeaker cables, do not trail them over open floor spaces where they could cause an accident. Cover them or route them around potential trouble spots.
 - Before switching on your sound system, turn the volume level down. After switching the system on, turn the level up gradually.
 - Do not use extreme settings of Treble, Bass or EQ. Ideally set the tone controls "flat" and turn any EQ off.
 - These loudspeakers are extremely heavy. Do not move them by yourself. Always get help.
- If you are using the floor spikes:**
- Spikes are sharp! Exercise extreme caution when using spikes.
 - Do not drag the loudspeaker. Lift the speakers off the floor and set them down carefully when changing their location.
 - Be especially careful not to place a spiked loudspeaker in areas where there may be hidden obstacles that could get damaged.
 - Some floor surfaces can be damaged by spikes. If you are unsure, consult your flooring contractor for advice before using spikes, or use the spike seats.

Introduction

For over 60 years, our engineers have sought the ultimate: a loudspeaker that could reproduce recorded music with all the passion of a live performance. The Palladium™ Series approaches aural perfection, while making a visual statement that is every bit as elegant and passionate as the sound.

The Palladium Series P-39F floorstander represents the epitome of loudspeaker technology, with remarkable clarity throughout the dynamic range and bold styling. Today, Klipsch Group, Inc. is a global force, and this flagship loudspeaker reflects that leadership status; design and engineering teams from the United States collaborated with colleagues from Germany and China to plan and execute the Palladium project.

In designing the Palladium P-39F cabinet, we first considered the Klipsch heritage and unique approach to acoustic design. Trends in home interior and furniture were also factored in, as was the current audio market landscape.

The result is a speaker that flawlessly melds classic Klipsch® audio with the latest in home furniture trends. The striking “boat-tail” design hints at the power and performance inside, while maintaining a high degree of sophistication and beauty. More importantly, the arched shape of the P-39F flagship loudspeaker actually contributes to its remarkable sound by breaking up standing waves at higher frequencies.

Power. Detail. Emotion. Combined, these qualities are the embodiment of our core philosophy. And all are expressed—beautifully—in the brilliant Palladium P-39F loudspeaker. We invite you, our customer, to share with us the pride of ownership in this extraordinary product for many gratifying years.



Getting Started

Unpacking

Please follow the unpacking instructions fully and in the order shown below. These loudspeakers are heavy! Do not lift or move these speakers by yourself. Always have someone help you.

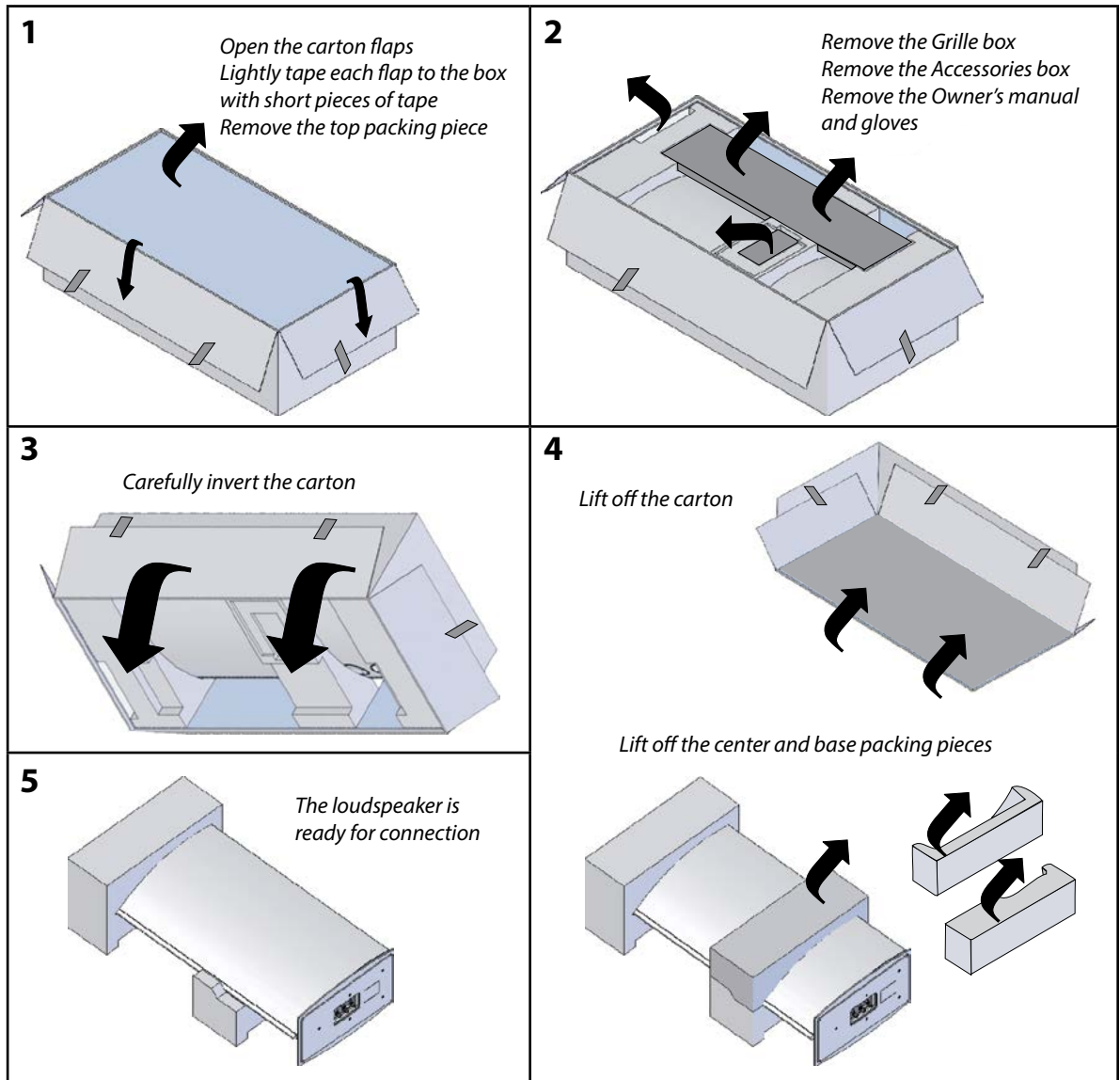

What's in the box?

- **The grille box contains:** one upper grille; one lower grille.
- **The Accessories box contains:** four long spikes; four short spikes; four spike seats; two bi-wiring straps; one Allen wrench.
- There is a pair of gloves located in a pocket in the side of the packing carton beside the Owner's manual.

Identify all the components. If any item is missing or damaged, report this immediately to your Klipsch dealer and the transport contractor for action.

Preparing the Loudspeaker

Connection Procedure:

There is a specific procedure to be followed:

- Switch off and unplug the amplifier/s and all source electronics from the mains power.
- Place both loudspeakers in the general area where you want them.
- Place each loudspeaker on its side, in its partial packing, as described in the unpacking instructions.
- Connect each loudspeaker.
- Attach the spikes following the instructions under the “finalizing the assembly” section of this manual.
- Position the loudspeaker cable between the rear spikes.
- Stand the loudspeaker upright, using great care not to damage connecting cables, furniture or the floor.
- Lift off the top packing piece and the protective cloth bag.
- Run both sets of loudspeaker cables to the amplifier.
- Connect the amplifier.
- Finalize the position of the loudspeakers.
- Finally, fit the grilles (if desired).

**TAKE CARE NOT TO TOUCH THE DRIVE UNITS WHEN YOU MOVE THE LOUDSPEAKERS AROUND.
TO PRESERVE THE FINISH, USE THE PROVIDED GLOVES WHEN HANDLING YOUR LOUDSPEAKERS.**

Fitting and Removing the Grilles

The grilles are magnetically attached to the cabinet. Specially designed magnets are housed inside the front wall of the loudspeaker, so that if you wish to operate the loudspeaker with the grilles removed, no grille mounting hardware is visible. This preserves the smooth lines of the loudspeaker.

To fit the grilles: Fit the top grille first and line it up with the top and sides of the cabinet. There is a small lip on the top of the grille that should rest on the top of the cabinet. Now, fit the lower grille, lining up the top of the lower grille with the bottom of the upper grille. You may now remove the top grille if you wish.

Although operating the P-39F loudspeakers with the grilles on or off is a matter of personal taste, moving or connecting the loudspeakers should always be done with the grilles removed. Be especially careful not to touch the drive units.



Positioning Loudspeakers - Stereo

Never allow objects of furniture to impede the loudspeaker or place objects between the loudspeakers and the listening position.

Stereo Positioning

The generally accepted norm is that the loudspeakers should be as far away from each other as they are from the listener. This places the listener and the loudspeakers at the points of an equilateral triangle. Well-designed horn loudspeakers have "controlled directivity" - the dispersion pattern is tailored to providing the ideal image at the listener's ear. This is in contrast to conventional speakers, where the sound tends to fire off in all directions.

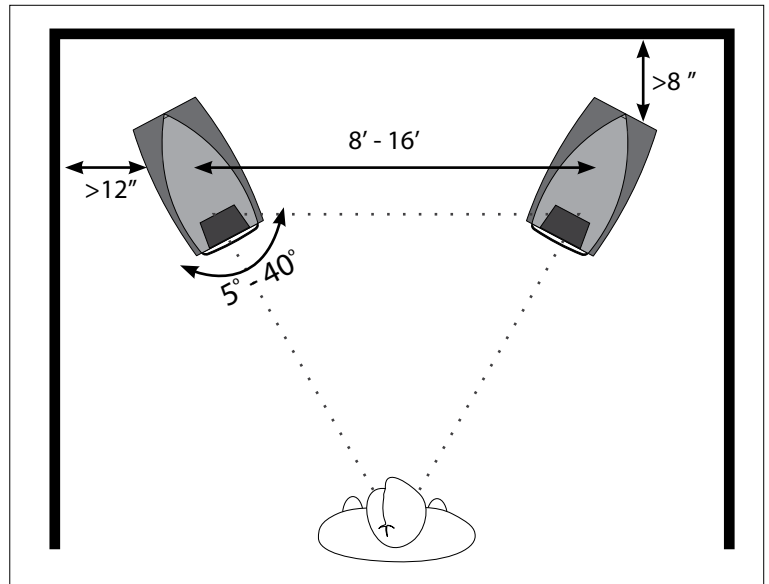

It follows that when correctly sited, the performance of a well designed horn loudspeaker significantly exceeds that of conventional "direct radiator" loudspeakers.

Because the bass drivers are in a tuned port enclosure, the loudspeakers must be operated away from walls and, specifically, corners. The distances in the above diagram should be considered as minimum distances. Placing them too close to the walls will cause the bass to become bloated, muddy and indistinct.

The angle at which the loudspeakers are placed relative to the rear wall is called "toe-in". Placing the loudspeakers with their backs parallel to the wall will result in a poor stereo image with the so called "hole in the wall" effect. Angling the speakers inwardly too much will restrict the width of the listening seat and also tend to narrow the stereo image.

In smaller rooms, it is better to place the loudspeakers more closely together and sit relatively further back. This is preferable to placing the loudspeakers further apart and sitting too close - the stereo effect will be significantly degraded if you do.

The height of the loudspeaker is important. The midrange should appear to radiate from a point level with the ears of a seated listener. As these loudspeakers are large, they will sound their best in large rooms, though there are some adjustments that can be made to redress the position in smaller rooms. These will be discussed in the section on final positioning.

The above are our recommendations. Be prepared to experiment until the sound is exactly as you want!

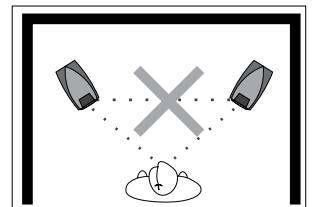
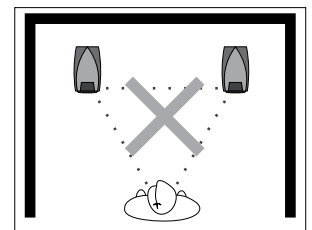

Positioning Loudspeakers - Home Theater

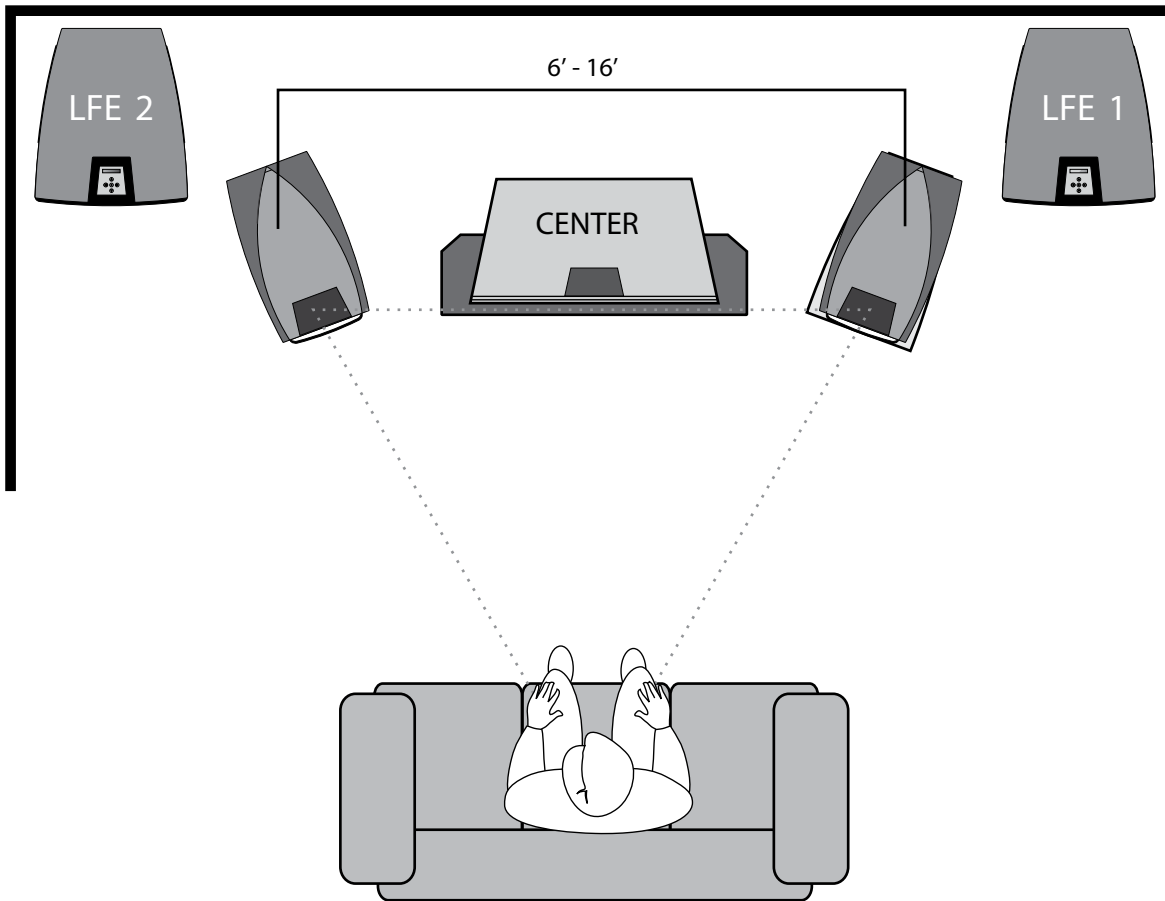

The same general positioning rules as for stereo apply but these are some variations.

- The loudspeakers can be placed closer together. Remember that the closer the speakers are to one another, the less spacious the sound will be in stereo.
- The “toe-in” can be lessened. This will broaden the sound image for more than one listener, but the pinpoint localization of the speakers will be lessened.
- The fronts of the speakers should be in line with the screen and with the front of the center loudspeaker as far as possible. Placing the TV screen on the wall (and center channel directly above or below) with the main loudspeakers protruding significantly is not ideal.
- The TV should be placed centrally between the loudspeakers.

The above are our recommendations. Be prepared to experiment until the sound is exactly as you want!

General Observations

- Set the size of the speakers on your AV processor to “large.”
- For stereo listening (if your processor offers the option) set the subwoofers to “off.” Alternatively, set the subwoofer lowpass crossover point such that it covers only the lowest octave; ~ 50 Hz.

Cables, Crossovers and Connections

For best results, connect your loudspeakers with purpose-designed loudspeaker cable. The cables to both loudspeakers should be of equal lengths and be of a gauge sufficient to drive the speakers comfortably without any loss of power in the bass at high volumes.

We recommend a minimum wire diameter of 14 AWG. If you are in doubt, ask your Klipsch dealer for advice. Because of the location of the terminal panel, you should connect the loudspeakers before you connect the amplifier. If you are replacing existing pair of loudspeakers, we suggest you de-wire the amplifier first.



There are two crossover networks in the P-39F. One panel is a dedicated bass network. The second panel is a network for the midrange and treble units. The networks terminate in a custom designed tri-wire terminal panel located above the loudspeaker pedestal, under the loudspeaker. As the bass, midrange and treble elements can be separately connected, three types of wiring are possible: standard wiring, bi-wiring and tri-wiring.

The terminal panel accepts a wide variety of connectors, including spade lugs, pins or bare wire. If you have no preference, your dealer can advise you as to appropriate connectors. The instructions in this user guide relate to bare wire. If you use alternative connectors, consult your dealer or the hardware supplier's literature.

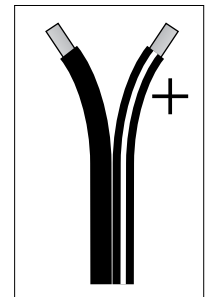

Standard loudspeaker cable comprises two conductors with one core having a ridge or stripe. Connect the striped conductor to the Positive (RED) terminal in all cases. This will ensure that the loudspeakers are properly connected and in phase.

Split the cable to a depth of 1½". Strip ½" of insulation. If the wire is stranded, lightly twist the ends together to ensure no stray ends of cable can short adjacent terminals.

Connecting a Terminal

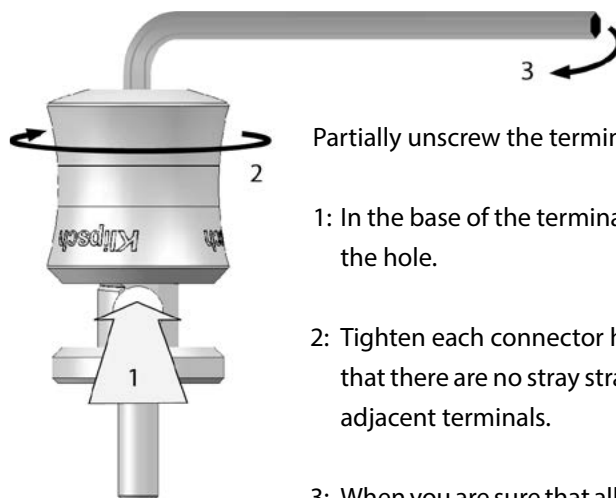

Partially unscrew the terminal.

- 1: In the base of the terminal, there is a hole. Insert the bare end of the wire into the hole.
- 2: Tighten each connector hand tight. After connecting all the terminals, check that there are no stray strands of bare wire that can reach across and short out adjacent terminals.
- 3: When you are sure that all the connections are correct, insert the Allen key into the socket in each terminal head and tighten fully to secure them. DO NOT over-tighten the terminals, or you may damage them. (An Allen key (hex wrench) is provided in the accessories carton.)

Connecting the Loudspeakers - 2

The P 39-F Terminal Panel

As supplied, positive and negative terminals of the Treble, Midrange and Bass Terminal pairs are strapped together with a three-way strap. A pair of two-way straps is provided in the accessories carton for bi-wiring. This is how you should prepare the terminal panel for each wiring option.

Standard Connection

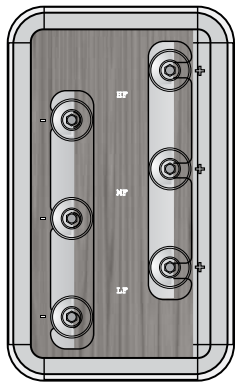

No preparation needed

Bi-wiring Connection

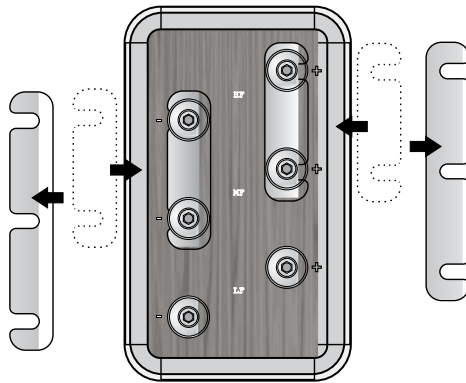

Loosen the terminals.
Remove the triple straps and insert the twin straps as shown
Re-tighten all terminals hand tight

Tri-wiring Connection

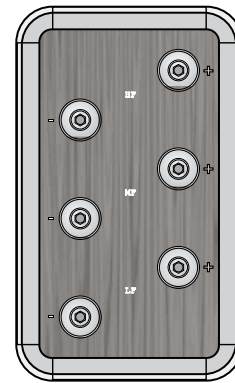

Loosen the terminals.
Remove the triple straps
Re-tighten all terminals hand tight

Standard (Single) Wiring

The straps are left in place as supplied. Connection may be made to any pair of terminals. You will need two loudspeaker cables of equal lengths, one for each loudspeaker.

Partially unscrew one Positive and one Negative terminal. Connect the Positive (+ RED) terminal of the loudspeaker to the striped conductor, or (if you are using custom cable) to the conductor designated by the cable manufacturer. Connect the Negative (- BLACK) terminal to the plain conductor. Do not connect the amplifier at this time.

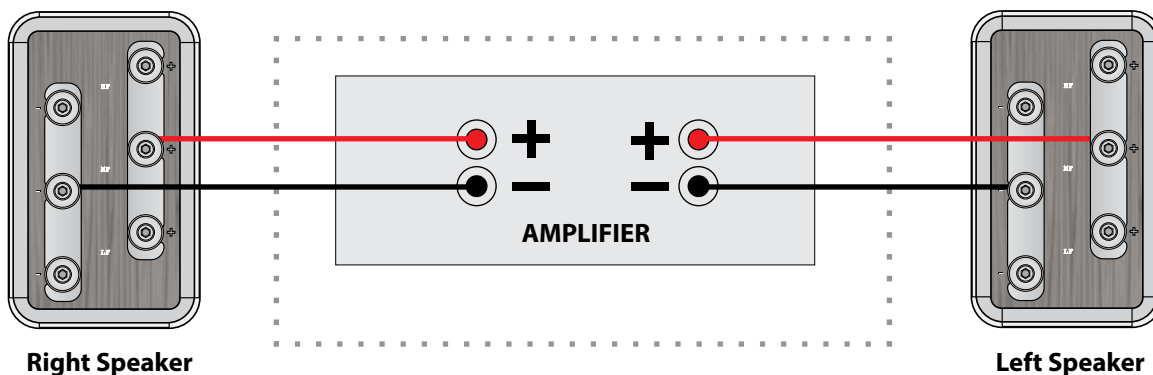

Important Note. After connecting and placing the loudspeaker upright, the connections will be hidden from view. We strongly recommend that you identify each cable to eliminate possible difficulties down the line.

Connecting the Loudspeakers - 3

Bi-wiring

Bi-wiring reduces unwanted interactions between the bass drivers and the midrange and treble units. True bi-wiring is connecting separate cables from the bass terminals and the midrange/treble terminals to a common connection at the amplifier. Several cable manufacturers produce specialized cables where one cable jacket contains four cables, thus enabling bi-wiring within one cable cluster. This eliminates the need to run separate cables and simplifies connection. In any case, the method of connection is the same.

Prepare the crossover panel as shown on the previous page. Proceed as for standard wiring, but connect one cable to the bass terminals of the speaker. Connect a second cable to the midrange and treble terminals. Refer to the diagram. After connection, tighten all the terminals with the supplied wrench as shown previously.

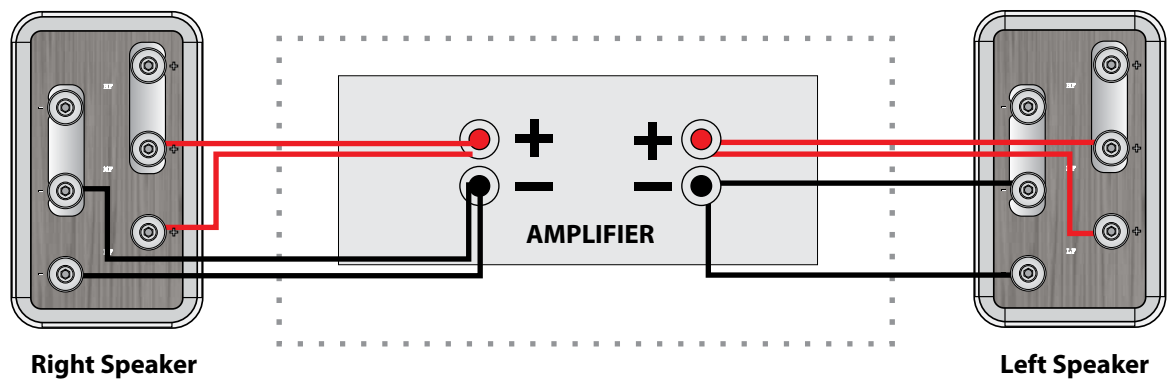

Tri-wiring

The logical extension to bi-wiring is tri-wiring, where all the elements of the loudspeaker are separately connected to the amplifier.

To tri-wire, you need to remove all the straps connecting the terminal pairs and then connect three cables as shown in the diagram below. After connection, tighten all the terminals with the supplied wrench as shown previously.

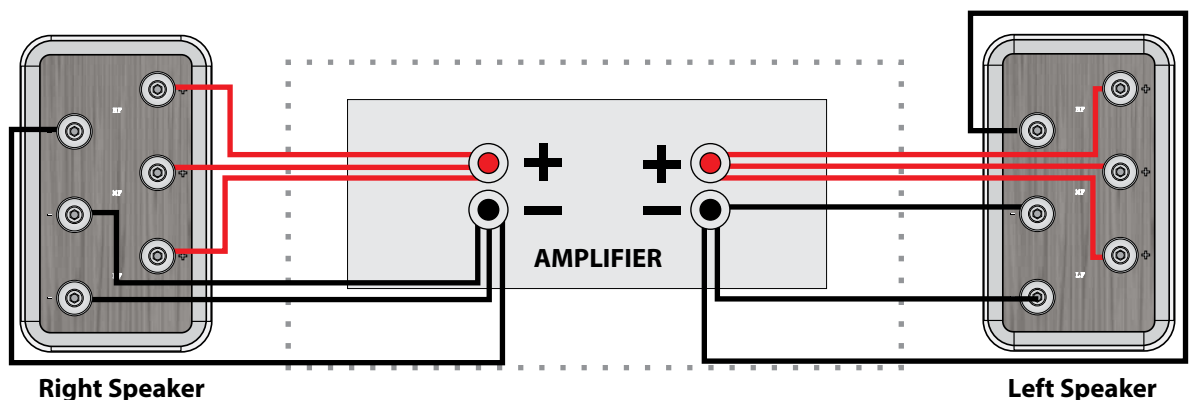

Important Note. After connecting and placing the loudspeaker upright, the connections will be hidden from view. We strongly recommend that you identify each cable to eliminate possible difficulties down the line.

Connecting the Loudspeakers - 4

Bi-amping and Tri-amping

Connecting each loudspeaker drive element to separate amplification offers the highest possible performance level. It is not necessary for the amplifiers in the treble and bass sections to be identical. In fact for tube amplifier enthusiasts, there are advantages to using smaller amplifiers in the treble and midrange sections as the smaller transformers offer the significant possibility of extended, sweeter treble response.

To multi-amp, the following criteria are essential:

- The amplifiers should be phase coherent. In other words, all amplifiers should be, by design, phase non-inverting or phase inverting, or if not, should be connected so as to be all phase non-inverting or phase inverting.
- The amplifiers must have identical voltage gains, or should be set up to have identical voltage gains.
- The amplifiers must have low residual noise characteristics, especially in the midrange and treble sections.
- Amplifiers in corresponding channels must be identical; i.e., both bass amplifiers must be the same and so on.

If any of the above conditions are not met, separate amplification will be significantly worse than ordinary bi- or tri-wiring. If you are unsure about these concepts or unsure if your amplifiers meet these criteria, it is essential that you consult your Klipsch specialist dealer before proceeding further.

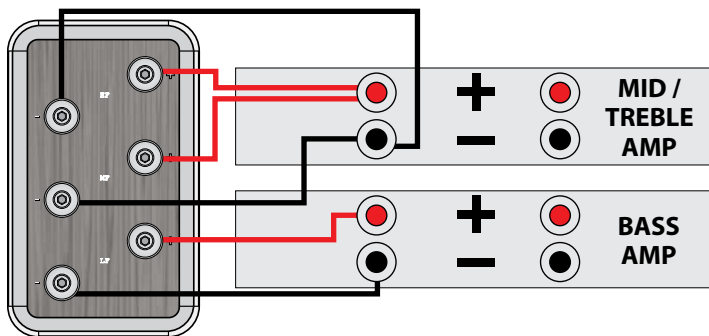

Bi-amping
The Mid/Treble amplifier is bi-wired
(One channel shown)

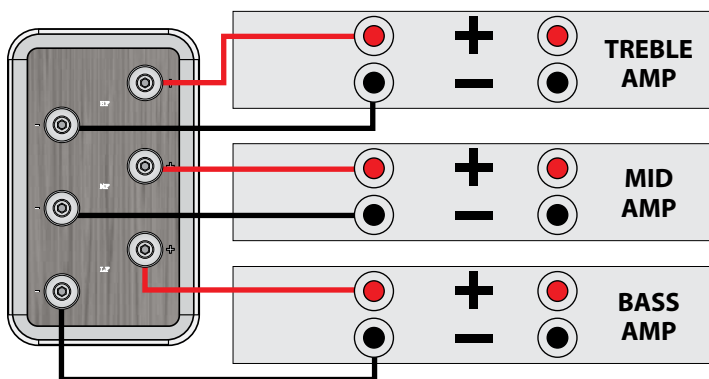

Tri-amping
(One channel shown)

Important Note. After connecting and placing the loudspeaker upright, the connections will be hidden from view. We strongly recommend that you identify each cable to eliminate possible difficulties down the line.

Finalizing the Assembly

Fitting Spikes

The loudspeakers are supplied with a set of long spikes and a set of short spikes. All are adjustable and fit in the same way. Spike seats with felt bases are supplied for use where spikes are inappropriate; e.g., on stone, hardwood or marble floors. The spikes may be fitted with sets of short spikes, sets of long spikes or as a combination of two short spikes at the front and two spikes at the rear to assist with imaging, (Refer to the next page)

Method: Run the textured collar halfway down the threaded shaft away from the spike point. Insert the shaft into the plinth and screw in tight. Now run the collar up to the plinth and lock it finger tight. Repeat for all four spikes.

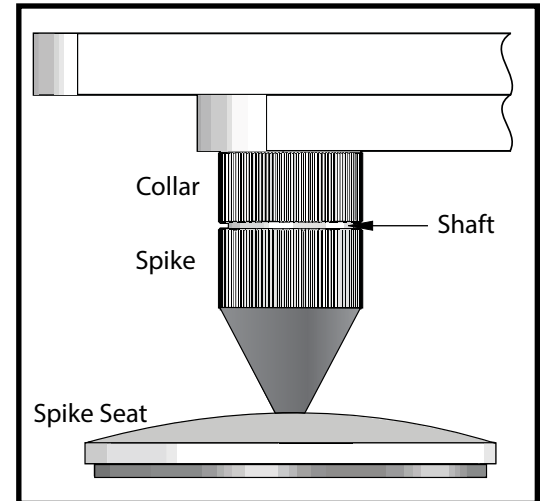

Hint: If you feel that you may have to move the speakers around a lot before you get them exactly right, it is advisable to start out with the spikes resting in their spike seats. This will allow you to easily slide the speakers on a hard floor surface. After finalizing the speaker position, you can then mark the position of the feet and remove the spike seats.

Caution: Regardless which size spike is used make sure the textured collar is threaded on the spike. Failure to do so could result in damage to the plinth.

Dressing the Cables

If there are more than one cable to each loudspeaker, gather them and lay them side by side. Make sure you have identification on all the cables. Ensure the cables are connected the same way round with no loose or faulty connections. Leave a small amount of slack and then bring the cables out between the spikes. It may be helpful to tape bi- or tri-wired sets side by side to the underside of the plinth to stop them from interfering with the spikes.

Standing the Loudspeakers Upright

With the help of an assistant, lift the speakers into the vertical position. The feet must be secure, as there will be a large amount of pressure on the two spikes that come into first contact with the floor.

Remove the top packing piece and the protective bag from the loudspeaker. Be careful to avoid touching any of the drivers.

You should now level the loudspeaker. If the floor is not perfectly level, you will find that one spike is off the ground. Starting with this spike and with the help of a spirit level, you should now adjust the spikes so the speakers do not wobble and are not at an angle. Try to get the speakers to the same height if at all possible.

Final Connections

Now, connect the loudspeakers to the amplifier/s using the diagrams on pages 8-11 to help you.

You are now ready to enjoy your music!

Final Adjustments

The P-39F has a phenomenal frequency response and superb dynamics, so playing large orchestral or rock music will be an awesome experience, but may not necessarily be the best guide in setting up the speakers. Your listening tests should be performed with a wide range of music, including unaccompanied vocal and solo instrumental recordings with as little processing on the source as possible. A natural solo cello recording will reveal much about the bass characteristics of your room and positioning. The best position will yield smooth, extended bass without boom or smear.

The loudspeakers are “handed” - the recommended position is with the bass ports facing outward. The ports distribute a lot of air at high bass volumes, so if the speakers appear to boom even slightly re-positioning them with the ports facing inward may help significantly.

Stridency in the upper section caused by underdamped rooms can be compensated for by hanging drapes or pictures on the walls to dampen reverberant walls; increasing the amount of soft furnishings will also help to eliminate high frequency “ringing”.

Room resonances are often structural. In such circumstances, good placement will minimize but not eliminate these resonances.

Apparent height is critical. The speakers have controlled directivity. In the P-39F, phase response anomalies are kept to vanishingly low levels by reducing the distance between the midrange and tweeter horns to the absolute minimum; nevertheless, if you are in the wrong seat, it may happen that the sound stage is not perfectly integrated. One remedy is to tilt the speaker slightly (if necessary by using a combination of long and short spikes) to aim the midrange driver at the listener’s ear to yield best driver integration. Take your time with this —the effects on some music may be small and quite startling on others.

Phase

Phase is not a matter of preference. Out-of-phase effects manifest themselves as poorly defined bass, poor stereo with very vague localization of instruments and voice, and generally fuzzy, ill-defined sound. A single-wired out-of-phase system is easy to detect; a tri-amped system with one element connected out of phase can be nearly impossible to track down. If you find that there are problems with the system that no amount of experimentation can cure, check all the loudspeaker and amplifier wiring carefully. If you have connected your speakers strictly in accordance with this manual, no phase problems will arise.

Conclusion

All the advice above will help you get the most out of these superb loudspeakers, but in the final analysis you should do what your ears tell you is right — you are, after all, the final arbiter of your system.

Happy listening!

About Your Loudspeaker

An International Project

The Klipsch P-39F has drawn on engineering, design and manufacturing resources from all over the world. In addition to our formidable team in the USA, we have used European industrial designers, British theoretical physicists and manufacturing and production specialists from China. The focal point of these resources is our birthplace, Hope, Arkansas, where, under the vigilant eyes of the most skilled manufacturers of horn loudspeakers anywhere in the world, your P-39F was built, tested, measured, evaluated in rigorous listening tests, and finally shipped.

The P-39F is the culmination of over 60 years of research and engineering advancements, having been designed with the most advanced computer aided design (CAD) tools available, rigorously evaluated using our own in-house proprietary software, built to the most stringent quality standards and voiced by a panel of our most experienced listeners. No Klipsch loudspeaker has ever had more care and attention to every detail lavished on it than your P-39F.

Although building one pair of matched loudspeakers is relatively straightforward, building hundreds of matched loudspeakers is challenging. Measurements play an important role in analyzing loudspeaker characteristics, but the human ear is the ultimate test gear for evaluating its reproduction quality. At Klipsch, every loudspeaker design is strictly evaluated using listening tests designed to expose even the very smallest weakness. All final voicing is performed under blind conditions, using trained listeners and standard audio sound tracks selected based on their particular area of auditory excellence. All information is tabulated and reported back to the designer for analysis. In almost all cases, Klipsch products are evaluated against similarly priced competitive models. It is only in this manner that Klipsch can truly rely on the quality of feedback received, eliminating skewed data that may result due to influences caused by price, brand recognition, or visual appeal.

Design

The P-39F is a 3.5-way bass-reflex full range loudspeaker with high sensitivity and extremely low distortion. The five drivers of the P-39F comprise three 9" woofers, an advanced 4.5-inch horn-loaded compression midrange driver, and a .75-inch titanium horn loaded compression dome tweeter. Each driver was designed by the Klipsch Engineering team and optimized for superior performance within each transducers bandwidth. Accurate driver design minimizes the need for driver corrections in the crossover network. Thus, the crossover is a straightforward design, with extremely high-quality components ensuring minimal insertion loss. By presenting a simple load to the amplifier, overall system performance is enhanced, a phenomenon rarely found with conventional designs. Each component used in the crossover, from the air core inductors to the polypropylene capacitors, has been selected to provide an undistorted transition between transducers. The superior components used in the P-39F are complemented by the unique horn and enclosure design and highlighted by the elemental performance of the industrial design. The massive laminated MDF enclosure is based on a curved non-parallel wall structure for minimal resonance. Both the tweeter and midrange compression drivers are integrated into a common molded two-element horn optimized for bandwidth, clarity, and efficiency.



Loudspeaker Components - 1

Bass Drivers

With 18-mm peak to peak linear excursion, and three 9-inch cones, the P-39F is capable of remarkably clean dynamic response down to a -3 dB point of 39 Hz.

The woofer utilizes a low mass hybrid Aluminum/Rohacell®/Woven Synthetic Fiber cone with an over hung voice coil. Even under massive dynamic demand, the driver retains linearity and low distortion. A three-part high intensity neodymium magnet is used with a main magnet, plus rear and forward magnets to ensure linearity, reduce stray magnetic energy and provide intense field strength in the voice coil gap. Dual Faraday rings on the pole piece minimize unwanted inductance, enhance heat dissipation and minimize dynamic compression.



The metal cone of the woofer is damped with a composite Rohacel and Woven Synthetic Fiber layers which minimizes ringing and maintains low mass, eliminating breakup and other distortion products. As is the case with the midrange driver, the surround uses a flat-sided shape that keeps surround-produced output to a minimum and preserves phase response. The cast aluminum frame assures maximum heat transfer without any reflection of the back wave of the driver that would otherwise alter the sound. An inverted half-roll low density foam rubber surround completes the clean appearance.



The woofers see differing pass bands. This preserves consistent dispersion through the critical woofer to midrange transition region and has a positive impact on off-axis performance and stereo imaging. This upper woofer covers the entire range from 30 Hz to 500 Hz, where it crosses over to the midrange driver, while the two lower woofers cover only the low and mid-bass. This “tapered-array” design delivers full bass impact, plus a graceful transition between driver groups in both tonal accuracy and dispersion.

Midrange - “The midrange is where we live.” Paul W. Klipsch

The inverted dome midrange driver operates from 500 Hz to 3.5 kHz and is a unique design, not found on any previous Klipsch product.

The driver sensitivity of 106 dB allows minimal excursion at normal playback volume. As cone excursion reduces, so does distortion. The 4.5-inch aluminum dome is driven by 3 high temperature N35H neodymium magnets, ensuring linearity under a range of listening volumes. The pole piece is topped by a copper cap to minimize unwanted inductive components. The surround has half the density of the material typically used and thus offers reduced mass. Unlike most designs, this midrange driver delivers much more output from the dome and less from the surround. As a surround is always in motion and always changing shape, output from its surface is high in distortion—minimizing surround surface area is another means to reducing overall distortion.

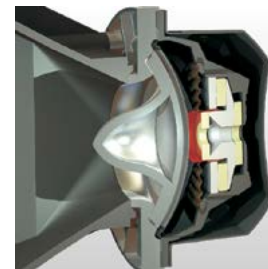

The midrange unit is housed in its own magnetically-shielded sealed enclosure, which isolates the driver from acoustic energy generated by the woofers. Every effort has been made to ensure great accuracy, as well as long-term durability from this unique driver.

Loudspeaker Components -2

Treble Compression Driver

Low distortion, high sensitivity, wide bandwidth and neutral tonality have been, in this ground-breaking design, pushed beyond the standards for any previous Klipsch driver.

Built around a .75-inch titanium dome, the tweeter makes use of two very large high temperature N35H neodymium magnets in an unconventional configuration. The titanium dome and surround are formed as one common unit.

The chamber behind the tweeter dome is resistively damped via a filled tube to reduce reflection of the back wave—and thereby the distortion that would otherwise be produced. The phase plug that puts the dome into a compression mode also has a unique chamber within it that extends the upper frequency limit of the driver. This proprietary technique offers numerous benefits, including the elimination of undesirable standing waves in the high pressure layer between the phase plug and horn. The result is a smooth impedance transfer function, and a benign load on the partnering amplifier. Additionally, this technique produces

smoother amplitude response through the high frequency range. With its unique horn and phase plug, the P-39F tweeter demands far less drive current from the amplifier, so the driver can maintain full dynamic capability at any volume level.

This driver is inherently flat from 3 KHz to 30 KHz. and has an inherent sensitivity some 10 dB greater than direct radiating designs. Distortion is also reduced by a factor of 10 dB, against conventional tweeters.

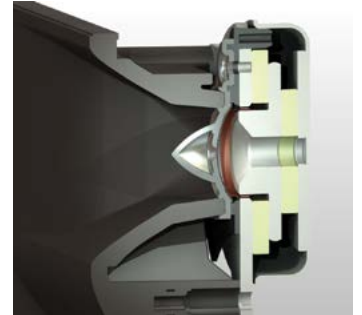

Crossover Network

The network is a two board construction located adjacent to the speaker's base plate, which conveniently positions the tri-wire input connectors at floor level. This minimizes the length of speaker wire and produces a clean finished look.

Through very accurate driver engineering, the system offers excellent performance without the need for corrections in the crossover network. A crossover should provide a smooth transition from driver to driver, allowing each element to operate at its optimum performance within its designed frequency range. This accomplished, the network can be a straightforward design and use extremely high quality parts without imposing unnecessary budget constraints. A simple, elegant crossover also means the speaker will have a more direct and coherent

Bass Network



Mid and Treble Network

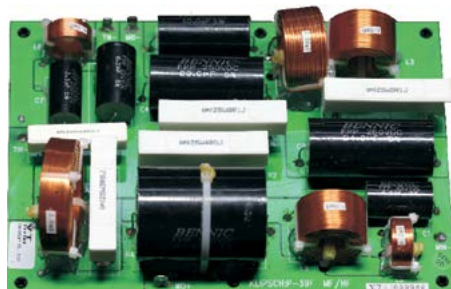

character as compared with products that must employ complex networks to iron out their shortcomings. Polyester capacitors along with all air-core inductors, ensure best performance and longevity. The network produces a fourth-order electro-acoustic filter when combined with the smooth, natural roll off of the drivers.

Loudspeaker Components -3

Cabinet

Functionally, any loudspeaker enclosure provides a mechanical placement of each transducer, a method for suppressing acoustical radiations and a resonant chamber to extend low frequency performance. The P-39F is an artistic blend of beauty and functional performance. Its industrial design was guided by the global consultancy of BMW Group DesignworksUSA.

Enclosure resonances can be suppressed through the geometry of the enclosure and mass of the panels. The P-39F enclosure contains nonparallel wall structures and thick, high mass walls. Nonparallel wall structures significantly

decrease standing waves. Cabinet wall thicknesses are a minimum of 1-inch thick with an even thicker front baffle. Custom inner and outer laminated panels sandwich a middle layer of dissimilar material designed with a different mechanical impedance to ensure the cabinet does not color the sound.



To further increase enclosure stiffness, four "H" braces are strategically positioned in the enclosure to reinforce the structure, control resonance and minimize modal standing waves. The massive front baffle design allows all woofers and the mid/high horn structure to mount flush to the exterior edge. The width of the front baffle has also been minimized to decrease the total area. A smaller front baffle directly correlates to improved off-axis performance. The overall enclosure was designed to extend the low frequency response of the three woofers to 39Hz (-3dB). This fourth-order, vented enclosure contains three custom flared, tuned ports cleverly blended into the rear of the curved enclosure. Just below the ports, a high mass aluminum and steel base is integrated into the bottom of the enclosure. The base contains four adjustable floor anchors, which decouple the cabinet from the floor by supporting the cabinet at just four points.

Tractrix® Horn Design

Horn-loaded technology is the driving force behind the remarkably accurate Klipsch sound. Horns offer high efficiency, low distortion, controlled directivity and flat frequency response, allowing them to more closely reproduce the quality and tonal characteristics of live sound. In the P-39F, the high and mid-frequency drivers both use the latest evolution of our Tractrix® Horn design, featuring a 90° x 60° coverage pattern and a lofted throat design for exemplary on-axis response. These horns have been molded as a single unit, using a proprietary, acoustically inert, carbon-infused thermoset composite material. The high- and mid-frequency drivers are connected to the horns via chamber-dampened phase plugs that result in a 4:1 compression ratio, delivering remarkable efficiency with astonishingly low distortion. This arrangement allows the P-39F to provide a unique combination of precision, clarity and effortless power.

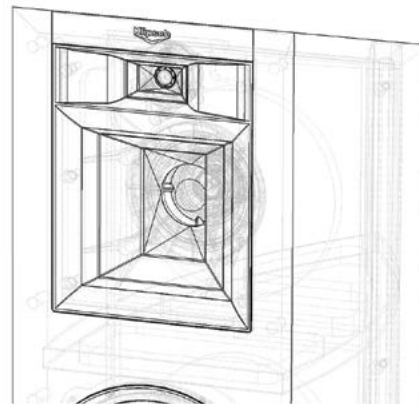

A Long, Long, Road...

Raw veneers



A raw cabinet pair



Work in progress...



Does it fit?



Drive Unit component inspection



Work in progress...



Ready for final assembly



Assembled and anechoically tested



Ready to pack and ship



Conclusion

Total Quality Management

To meet the rigid quality standards set at Klipsch, an extensive manufacturing audit is in place. All transducers are within ± 0.5 dB of the reference standard. Once all transducers are measured, they are grouped into matched sets. All matched transducers are then installed into the enclosure and measured again as a completed loudspeaker. Again, the speakers are sorted as matched pairs. The speakers are paired to ensure the most accurate imaging and stereo performance. At the end of the manufacturing process, the speaker is shipped with a hand-signed document, depicting each loudspeaker's performance. When a P-39F is shipped, it has completed the most rigorous testing of any speaker on the market.

Care and Maintenance

Very little maintenance is required. To maintain the finish of the loudspeakers, wipe them carefully with a soft lint free polishing cloth. Occasionally, and to remove fingermarks etc., wipe the cabinets with a barely damp clean soft cloth and finish with a lint free polishing cloth. NEVER use any form of spray, furniture polish, saturated polishing cloth, or the like. Doing so will dull and streak the fine finish of the cabinets.

Do NOT use a vacuum cleaner to clean the grilles while they are installed on the cabinet. To clean the grilles, remove them, brush them out by hand with a soft brush and replace them. Never touch the drive units either with your hands or with any tool or other object. This may damage the drive units irreparably.

Warranty

The Warranty below is valid only for sales to consumers in the United States and Canada. KLIPSCH, L.L.C. ("KLIPSCH") warrants this product to be free from defects in materials or workmanship (subject to the terms set forth below) for a period of five (5) years from the date of purchase. During the Warranty period, Klipsch will repair or replace (at KLIPSCH's option) this product or any defective parts (excluding electronics and amplifiers). For products that have electronics or amplifiers, the Warranty period on those parts is for a period of two (2) years from the date of purchase. To obtain Warranty service, please contact the KLIPSCH authorized dealer from which you purchased this product. If your dealer is not equipped to perform the repair of your KLIPSCH product, it can be returned, freight paid, to KLIPSCH for repair. Please call KLIPSCH at 1-800-KLIPSCH for instructions. You will need to ship this product in either its original packaging or packaging affording an equal degree of protection. Proof of purchase in the form of a bill of sale or receipted invoice, which is evidence that this product is within the Warranty period, must be presented or indicated to obtain Warranty service. This Warranty is invalid if (a) the factory-applied serial number has been altered or removed from this product or (b) this product was not purchased from a KLIPSCH authorized dealer. You may call 1-800-KLIPSCH to confirm that you have an unaltered serial number and/or you purchased from a KLIPSCH authorized dealer. This Warranty is valid only for the original purchaser and will automatically terminate prior to expiration if this product is sold or otherwise transferred to another party. This Warranty does not cover cosmetic damage or damage due to misuse, abuse, negligence, acts of God, accident, commercial use or modification of, or to any part of, the product. This Warranty does not cover damage due to improper operation, maintenance or installation, or attempted repair by anyone other than KLIPSCH or a KLIPSCH dealer which is authorized to do KLIPSCH warranty work. Any unauthorized repair will void this Warranty. This Warranty does not cover product sold AS IS or WITH ALL FAULTS. REPAIRS OR REPLACEMENTS AS PROVIDED UNDER THIS WARRANTY ARE THE EXCLUSIVE REMEDY OF THE CONSUMER. KLIPSCH SHALL NOT BE LIABLE FOR ANY INCIDENTAL OR CONSEQUENTIAL DAMAGES FOR BREACH OF ANY EXPRESS OR IMPLIED WARRANTY ON THIS PRODUCT. EXCEPT TO THE EXTENT PROHIBITED BY LAW, THIS WARRANTY IS EXCLUSIVE AND IN LIEU OF ALL OTHER EXPRESS AND IMPLIED WARRANTIES WHATSOEVER, INCLUDING BUT NOT LIMITED TO, THE WARRANTY OF MERCHANTABILITY AND FITNESS FOR A PRACTICAL PURPOSE. Some states do not allow the exclusion of incidental or consequential damages or implied warranties so the above exclusions may not apply to you. This Warranty gives you specific legal rights, and you may have other rights, which vary from state to state.

Warranty Outside The United States and Canada

The warranty on this product, if it is sold to a consumer outside of the United States or Canada, shall comply with applicable law and shall be the sole responsibility of the distributor that supplied this product. To obtain any applicable warranty service, please contact the dealer from which you purchased this product, or the distributor that supplied this product.



3502 Woodview Trace, Suite 200
Indianapolis, Indiana 46268 USA
1.800.KLIPSCH • www.klipsch.com

